

Wheel flange lubrication trams



 **Tribotec**

Central lubrication / Hydraulics

Systems for Rail vehicles

Wheel flange lubrication for trams OK-01

Nowadays high requirements are placed on efficiency, cost reduction and environmental protection in demanding operating conditions of rail transport. High requirements are also placed on reducing the wheels re-profillation and rail track repairs costs as well as a noise reduction of rail transport. Special lubrication systems have become a perfect solution, which significantly eliminate the amount of wear wheels and rails, and also reduce the noise of vehicles at the same time.

TRIBOTEC produces Wheel flange lubrication systems as effective and economic solutions for wide range of applications across the whole spectrum of rail vehicles and type of rails.



Wheel flange lubrication OK-01 is designed for trams which are not equipped with pressure air distribution. The system works on the principle of applying lubricant mixture to the contact area of tram wheel flanges with rails by means of pressure air.

The grease inside the reservoir is sucked in with the piston dosing unit of the lubrication pump. The pneumatic dosing unit is operated by the solenoid valve. The exact amount of grease is dosed into a pressure air in a mixer, where the homogeneous greasing mixture is being made. The mixture of grease and air flows through a divider and piping on the vehicle's bogie into the spraying nozzles. The mixture is spread through the nozzles in the regular cycles on the exact grease point in the wheel flange. All the functions are switched on by freely programmable operating system.

Wheel flange lubrication OK-01 is adapted to use a higher consistency of plastic lubricants, mineral lubricants with a high graphite proportion or biodegradable lubricants. It is capable of operation in a wide range of climatic conditions and in the difficult external operational environment.

Lubrication systems OK-01 are made in multiple variants to comply with installations on all types of tram, including the fully low-floor vehicles. They are characterized by minimization of build-in dimensions, very low weight, economic requirements for input power and low noisiness of the system. These characteristics and easy modifiability of construction type according to a particular project provide for trouble-free installation both in the vehicle interior and on its undercarriage.

Wheel flange lubrication OK-01 is delivered with open architecture system control at three basic levels of control methods and checking over the system operation:

- Direct control from the vehicle's master control system, possibly complemented with its own control unit for controlling according to vehicle mileage with respecting of the vehicle speed;
- The automated control from its own sensor, identifying the curve track (curve track lubrication);
- The intelligent adaptive control from the GPS system, operating with its own background maps and software algorithms, optimizing the lubrication process, depending on external environment effects and on internal characteristics of the vehicle travelling on a particular track.

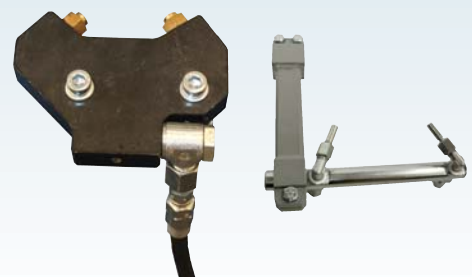



Benefits

Basic technical data

Supply voltage	24 V DC +25 % -30 %
Maximum current	10 A
Maximum air pressure	10 bar
Working air pressure	3.5 ÷ 7 bar
Lubricant tank capacity	according to design, 4 / 8 / 10 / 15 / 20 liters
Lubricant dose	0.4 cm ³ / cycle
Spray operating time	2 ÷ 3s (adjustable)
Lubricant	grease NLGI 000, others on request*
Weight	according to design, 27 ÷ 55 kg
Noise level	50 dB(A) + 10 dB(A)
Working environment temperature	-35 °C až +70 °C
Service life	20 years

* Using the biodegradable grease is possible. In case of using grease containing solid particles contact our specialists. The list of grease on request.

- Reduction of costs connected with replacement of wheels due to the wear of flanges
- Reduction of wear and deformation of rails
- Significant reduction of noise from passing vehicle, especially at railway switches and on bends
- Saving of energy by reducing friction between the flange and the rail
- Shortening of frequency and length of the vehicle's idle time due to repairs
- Reduced risk of a vehicle derailing
- Exact application of a thin film of grease, preventing the leakage from moveable components and clogging the brakes
- Economic grease consumption
- Using biodegradable grease, environmentally friendly
- Easy to apply, low demands on maintenance

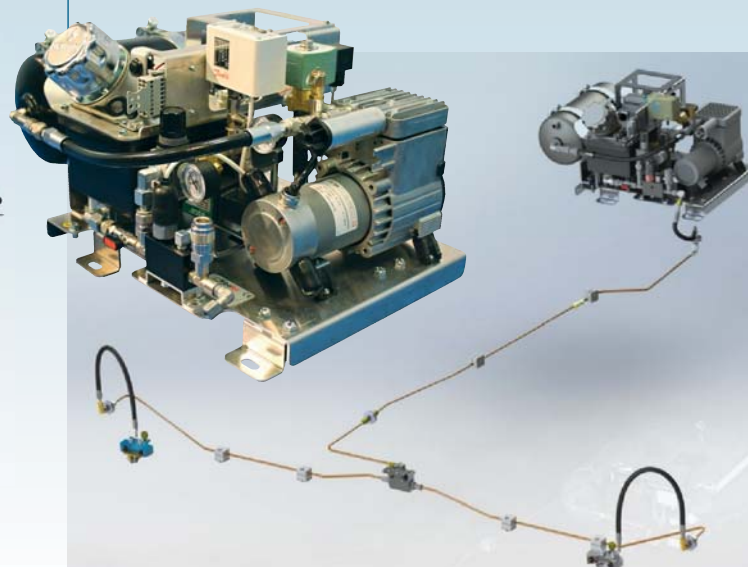
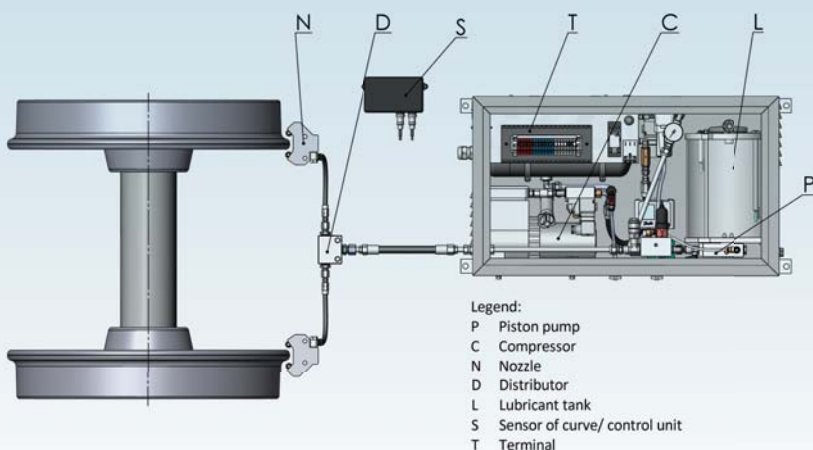



TRIBOTEC is a Czech manufacturing company concentrating on deliveries of central lubrication systems, lubrication technology, hydraulic systems and special systems for rail transport.

The company produces central lubrication systems, multi-line, progressive, two-line and single-line systems for lube oils and plastic lubricants up to the consistency NLGI-3, systems for oil re-circulation lubrication and oil cooling, spray lubrication systems with application for plastic lubricants and oils, oil-air lubricating systems, mobile and portable lubricating pumps.

In hydraulic systems, the company concentrates on production of hydraulic aggregates in the customer's design and a complex solution incorporating the project, production and delivery of the hydraulic systems, including special hydraulic systems for rail vehicles and rail transport.

As special products for railways TRIBOTEC produces systems of Wheel flange lubrication for trams and locomotives, Sanding systems for trams and locomotives and Stationary track lubrication for lubricating rail curves.

Both sale and manufacture activities are based on a mutual cooperation and on processing each individual project according to the customer's demands. The company provides installations and assemblies in the customer's destination, including commissioning and optimizing the operation, with after-sales service, preventive maintenance and consultations.

Its products are designed as a building kit, which enables wide modifications according to the specific technical data without increasing the project's costs. The company designs all drawings in 3D modelling and has established SW sharing the customer's documentation in order to implement the models directly in their documentations.

All business activities are in conformity with the quality management system ISO 9001:2008



www.tribotec.cz

TRIBOTEC, spol. s r.o.

Košuličova 4, 619 00 Brno, Czech Republic

phone: +420 543 425 611, +420 543 425 613

fax: +420 543 212 328

e-mail: tc@tribotec.cz